

FEATURES

- IEEE802.3af full functional compliance
- Short circuit protection
- Isolated DC out
- 3.3V, 5V, 12V & 15V output options
- On board UL recognised DC/DC converter
- Thermal shutdown
- Output voltage present LED
- UL 94V-0 flammability

DESCRIPTION

The NMPD01 series of power extraction modules has full functional compliance with IEEE802.3af. They are designed to extract power from CAT5 Ethernet cable when sourced by a Power Sourcing Equipment (PSE) also conforming to IEEE802.3af. The NMPD01 series removes the need for localised equipment power source, significantly reducing installation costs. The IEEE802.3af standard allows for two power options, one on the data lines, the other on the spare pair (see figures 1 and 2). The NMPD01 series can have voltage input on the data lines or spare pairs.

The NMPD01 series provides full signature and control as required by the PSE.

SELECTION GUIDE

Order Code	Nominal Input Voltage	Output Voltage	Efficiency ¹ (MIN.)	Power (MAX.)
	V	V	%	W
NMPD0103	48	3.4	74	9.5
NMPD0105	48	5.1	77	9.75
NMPD0112	48	12.1	80	10
NMPD0115	48	15.1	79	10

INPUT CHARACTERISTICS

Parameter	Conditions	MIN.	TYP.	MAX.	Units
Specified operating range		36		57	V
Turn on threshold	Voltage rising	36	40	42	
Turn off threshold	Voltage falling	30	31	33	
Input reflected ripple				50	mV p-p
802.3af Power classification	Class 0				
Signature resistance		23.75		26.25	kΩ
Signature capacitance		50	100	120	nF
Classification current				4	mA

OUTPUT CHARACTERISTICS

Parameter	Conditions	MIN.	TYP.	MAX.	Units
Voltage set point accuracy	100% load after 30 mins at nominal supply voltage			1.6	%
Overall voltage error	Case temperature -40°C to 110°C Load 0% - 100% Input specified range		1	2.5	%
Temperature coefficient of output voltage (slope)	Over any 10°C span within the specified temperature range		50	250	ppm°C
Deviation of output voltage	Specified over temperature MIN-MAX		0.5	1	%
Line regulation	Operating voltage range, 50% load		0.05	0.1	%
Load Regulation	0% - 100% rated load			0.5	%
Ripple	rms		70		mV
Switching frequency		330	350	395	kHz

COUPLING CHARACTERISTICS

Parameter	Conditions	MIN.	TYP.	MAX.	Units	
Insertion loss	1-100MHz			-1.2	dB	
	Return Loss	1-30MHz, at 100Ω	-16			
		40MHz, at 100Ω	-14			
		50MHz, at 100Ω	-13			
60-80MHz, at 100Ω		-12				
Differential to common mode rejection	30MHz	-43				
	60MHz	-37				
	100MHz	-33				
Cross talk	30MHz	-45				
	60MHz	-40				
	100MHz	-35				
DC resistance balance				≤3.5%		

ABSOLUTE MAXIMUM RATINGS

Input voltage	±60V
Output voltage	-0.3V to controlled output voltage (operating or non-operating)

All specifications typical at T_A=25°C, nominal input voltage and rated output current unless otherwise specified.

1. Nominal V_{IN}, full load.



ISOLATION CHARACTERISTICS					
Parameter	Conditions	MIN.	TYP.	MAX.	Units
Isolation test voltage	Flash tested for 60 seconds	1200			VAC rms

TEMPERATURE CHARACTERISTICS					
Parameter	Conditions	MIN.	TYP.	MAX.	Units
Case temperature	Full load	-40		110	°C
Storage	Absolute MAX. internal temperature	-40		125	
Relative humidity	Non condensing 85°C			85	%
Thermal protection	Operates at case temperature	110			°C

THERMAL CHARACTERISTICS				
MAX. power rating with case temperature maintained by external means (e.g. forced air cooling).				
Part Number	Case Temperature			Units
	100°C	105°C	110°C	
NMPD0103	9.5	7.0	1.0	W
NMPD0105	9.75	4.7	1.0	
NMPD0112	10	8.0	0	
NMPD0115	10	7.5	0	

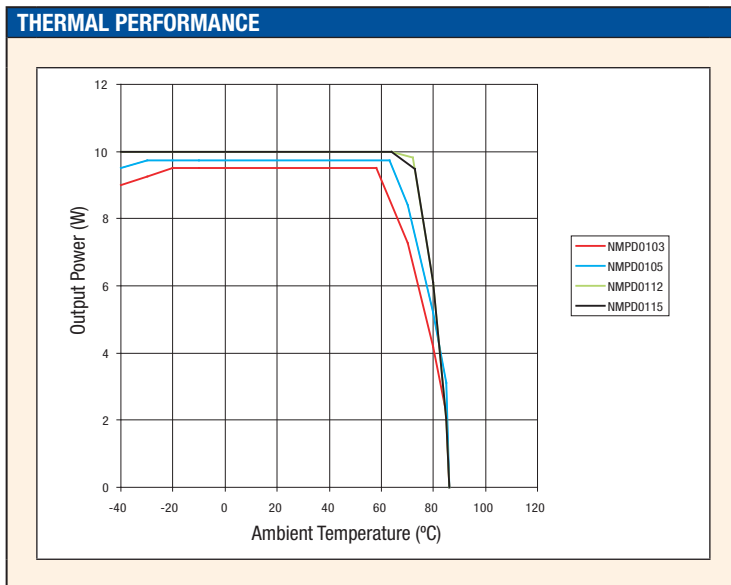

TECHNICAL NOTES

ISOLATION VOLTAGE

'Hi Pot Test', 'Flash Tested', 'Withstand Voltage', 'Proof Voltage', 'Dielectric Withstand Voltage' & 'Isolation Test Voltage' are all terms that relate to the same thing, a test voltage, applied for a specified time, across a component designed to provide electrical isolation, to verify the integrity of that isolation.

C&D Technologies NMPD01 series of power over ethernet modules are all 100% production tested at their stated isolation voltage. This is 1200VAC for 60 seconds.

A question commonly asked is, "What is the continuous voltage that can be applied across the part in normal operation?"

The NMPD01 series has an on-board DC/DC converter, that has been recognized by Underwriters Laboratory. Both input and output should normally be maintained within SELV limits i.e. less than 42.4V peak, or 60VDC. The isolation test voltage represents a measure of immunity to transient voltages and the part should never be used as an element of a safety isolation system. The part could be expected to function correctly with several hundred volts offset applied continuously across the isolation barrier; but then the circuitry on both sides of the barrier must be regarded as operating at an unsafe voltage and further isolation/insulation systems must form a barrier between these circuits and any user-accessible circuitry according to safety standard requirements.

REPEATED HIGH-VOLTAGE ISOLATION TESTING

It is well known that repeated high-voltage isolation testing of a barrier component can actually degrade isolation capability, to a lesser or greater degree depending on materials, construction and environment. While manufactured parts can withstand several times the stated test voltage, the isolation capability does depend on the wire insulation. Any material, including this enamel (typically polyurethane) is susceptible to eventual chemical degradation when subject to very high applied voltages thus implying that the number of tests should be strictly limited. We therefore strongly advise against repeated high voltage isolation testing, but if it is absolutely required, that the voltage be reduced by 20% from specified test voltage.

APPLICATION NOTES

The NMPD01 series are ideal modular system blocks for integration into numerous ethernet products to be powered from the data lines. These modules eliminate the need for localised powering saving considerable installation costs and time. These modules are ideal for applications where powering from the PSE at an SELV level is highly desirable such as in harsh industrial environments (chemicals and moisture).

Offering a module solution, incorporating ethernet isolation transformers, full compatibility signature to the PSE and isolated on-board DC/DC converter the NMPD01 series offers simple and quicker product development, maximising return on investment. PoE is the emerging standard in what is in effect the widest form of distributed power architecture.

Power-Up Sequence

A PSE applies two separate input voltages of <10V and calculates the signature resistance and signature capacitance of the POE device. If it is in the valid range, the PSE then applies a voltage between 14.5V and 20.5V and measures the classification current. If the classification current is between 0-4mA it is classification 0. PSE applies full operating voltage 42-57V, detection circuitry within NMPD1 senses correct voltage and turns on on-board DC/DC converter. If input voltage falls outside specified operating range, the on-board DC/DC converter is disabled.

Maximum Power

If the maximum output power is exceeded, the NMPD01 will operate in over current mode and will auto recover when the over load condition is removed.

Application Sectors

- Security system, door access, cameras, alarms
- Displays
- Public address systems
- Wireless access point
- Environmental control
- Telemetry
- Remote environmental monitoring

TYPICAL CONFIGURATIONS

Figure 1 - IEEE802.3af Power Configurations

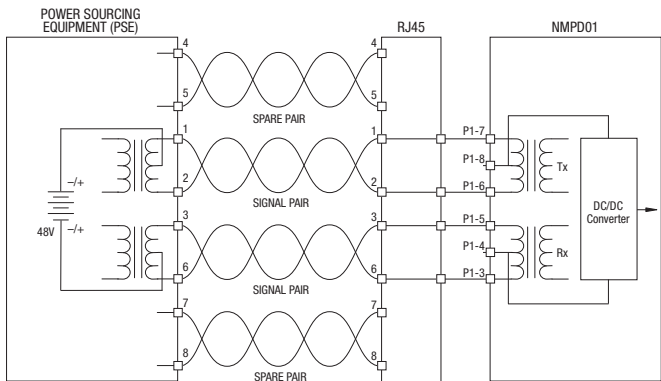

Signal lines carry both data and power.
Polarity of power is not important ... for both

Figure 2 - IEEE802.3af Power Configurations

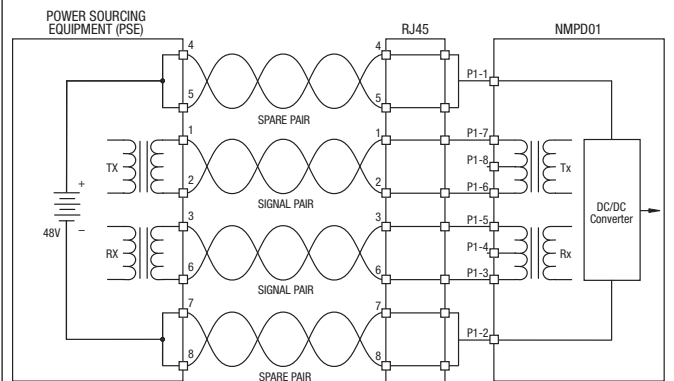

Spare pairs carry power, data lines carry data only.

Figure 3 - Typical non-powered coupling between CAT5 and Physical Layer Interface (PHY)

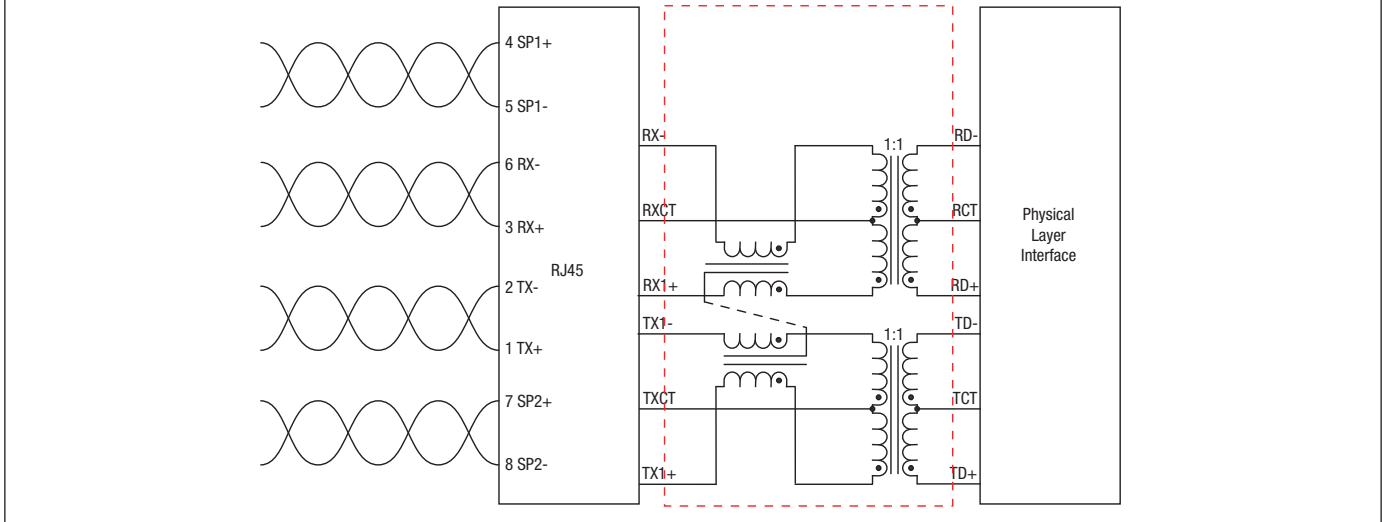
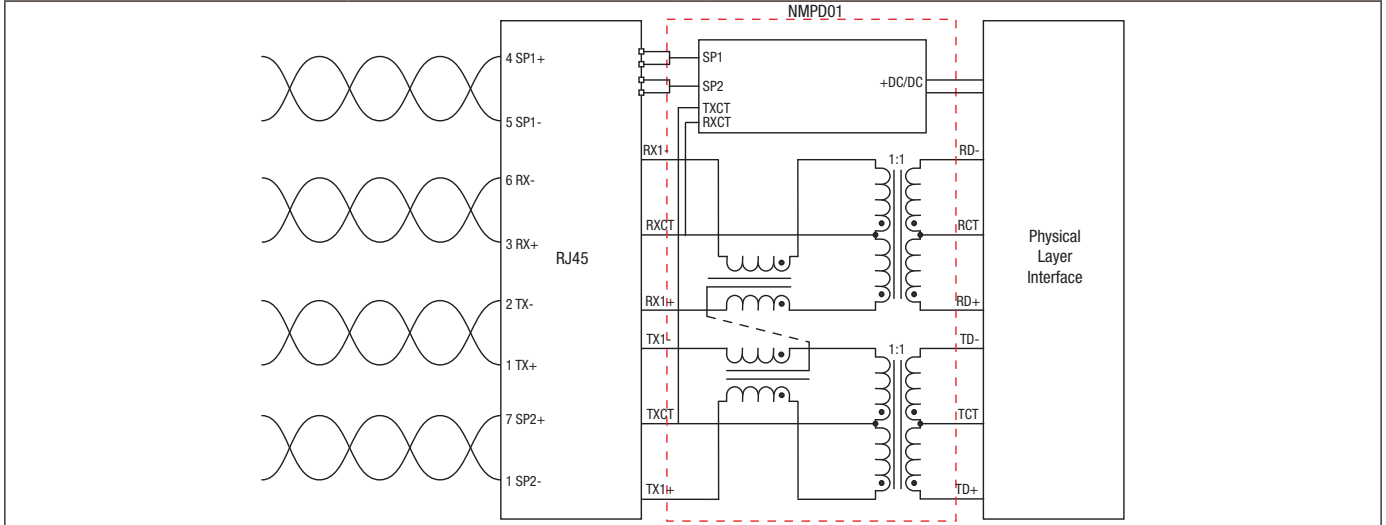
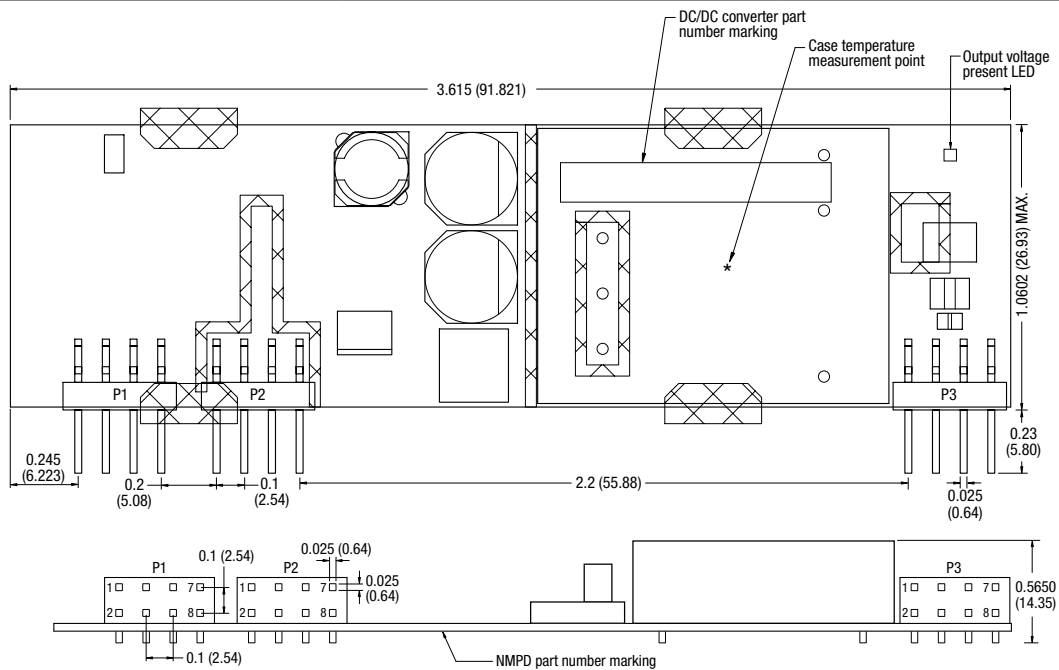

Figure 4 - Typical power coupling using the NMPD01



PACKAGE SPECIFICATIONS

MECHANICAL DIMENSIONS



Typical package weight: 35.6g
All dimensions in inches ± 0.01 (mm ± 0.25)

PIN CONNECTIONS

P1 - Data/power input	P2 - Data out	P3 - Power out
1 'B' +ve	1 TX+	1 +ve
2 'B' -ve	2 TXct	2 +ve
3 RX-	3 RX+	3 +ve
4 RXct	4 TX-	4 +ve
5 RX+	5 RX-	5 -ve
6 TX-	6 RXct	6 -ve
7 TX+	7 N/C	7 -ve
8 TXct	8 N/C	8 -ve

RECOMMENDED FOOTPRINT

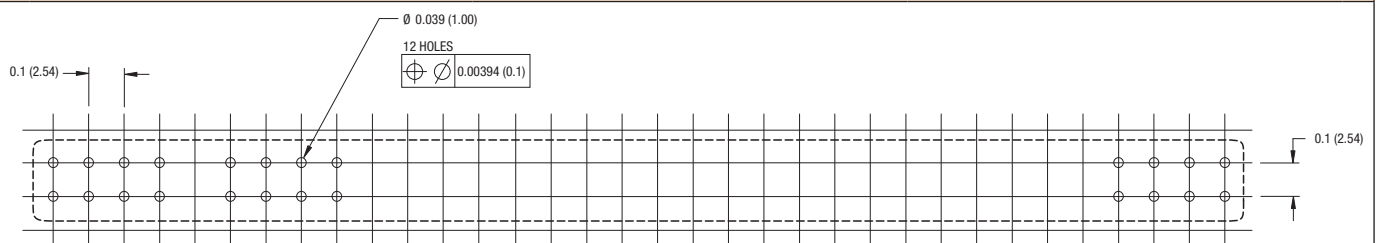

All dimensions in inches ± 0.01 (mm ± 0.25). All pins on a 0.1 (2.54) pitch.

The NMPD series is not suitable for aqueous washing.