

FEATURES

- RoHS compliant
- 48 V_{IN}, Isolated, 5:1 fixed conversion ratio
- 240W output at 38 V_{IN}, 55°C, 200 LFM
- 300W output at 48 V_{IN}, 55°C, 200 LFM
- Industry standard 1/8 brick footprint
- Remote enable (primary side, positive or negative)
- Over-temperature, over current protections
- Direct parallel operation for higher power

DESCRIPTION

The EUS34-096 is a RoHS compliant fixed 5:1 ratio bus converter in an industry standard eighth brick footprint to support Intermediate Bus Architecture (IBA) for powering multiple downstream non-isolated point-of-load (POL) converters. The output is unregulated and the 5:1 fixed ratio is maintained between the input and output voltages. It features input voltage range of 38V to 55V, and provides up to 300W @ 48V_{IN} of power. Typical efficiency of 9.6V module is 96%. It can be parallel for more power.

INPUT CHARACTERISTICS

Parameter	Conditions ¹	Min.	Typ.	Max.	Units
Input voltage operating range		38	48	55	V _{DC}
Input voltage absolute maximum				60	V _{DC}
Input undervoltage lockout	Turn-on threshold	34	35.5	36	V _{DC}
	Turn-off threshold	32	33.5	34	V _{DC}
	Hysteresis voltage		2		V _{DC}
Input overvoltage lockout (latching type)	Turn-off threshold	57	58.5	59.5	V _{DC}
Maximum input current	Steady-state (34 A out)		6.7		A _{DC}
No-load input current	Enabled state, no load (48 V _{IN})		100		mA
Disabled input current	Disabled state (48 V _{IN})		7		mA
Input reflected ripple current	Measured into the input pin Input capacitor 47µF type Nichicon UPM1J470MPH or equivalent			240	mA rms
Inrush current				51	A
Enable - negative logic version Internal 27.4 KΩ pulled-up to internal 5.0V	On state range	-0.1		0.8	V _{DC}
	Off state range	2.4		15.0	V _{DC}
Resistance from enable pin to -V _{IN}	With +V _{IN} pin open, or tied to -V _{IN}		TBD		KΩ

OUTPUT CHARACTERISTICS

Parameter	Conditions ¹	Min.	Typ.	Max.	Units
Output voltage set point	V _{IN} = 48V, I _o = 0A	9.40	9.50	9.60	V _{DC}
Output load regulation	I _o = 0 to 34A		0.4		V
Output voltage total regulation	V _{IN} = 38 to 55V, I _o = 0 to 34A, T _a = 55°C	7.0		11.0	V _{DC}
Output ripple & noise ²	20MHz bandwidth		50	150	mV p-p
Output current operating range	Corresponding to P _o = 240W	0		34	A
Efficiency	V _{IN} = 48V, P _o = 240W		96		%
Turn-on delay	From enable, <0.8V to V _o > 10% for V _{IN} = 38V - 55V		0.1	10	ms
Output voltage rise time ³	From 10% to 90%		10	15	ms
Start-up inhibit time	Enabled: V _{IN} applied to 90% V _{OUT}		150		ms
Transient response ³	25% step, 1A/µs, ΔV _o		±3		%V _o
Current sharing accuracy	At P _o = 240W		3	10	%
Output turn on overshoot			0	3	%
Output turn off undershoot			0	3	%
Maximum output capacitance				3000	µF

¹ V_{IN} = 48V_{DC}, T_a = 25°C, Airflow = 200 LFM for all data unless otherwise noted.

² Output Ripple Voltage and noise is specified when measured with a 10µF tantalum and a 1µF ceramic capacitor at the output pins.

³ During output voltage rise time (15 mS Max.), output power shall be limited to 50% constant power.

Transient response is specified with a 960µF capacitor at the output of the converter.



PROTECTION CHARACTERISTICS					
Parameter	Conditions ¹	Min.	Typ.	Max.	Units
Output over-current shutdown ²	Auto-restart	38	40	42	A
	Re-start rate		TBD		ms
Over temperature shutdown ³	Auto-restart		135	140	°C
Over temperature restart hysteresis			10		°C

GENERAL CHARACTERISTICS					
Parameter	Conditions	Min.	Typ.	Max.	Units
Isolation voltage	Input to output	2250			V _{DC}
Isolation resistance	Input to output	10			MΩ
Storage temperature range	Non-condensing	-40		125	°C
Operating temperature range		-40		85	°C
Operating humidity	Non-condensing	10		90	%
Thermal measurement location temperature ³	See mechanical drawing for location			130	°C
Material flammability	UL 94V-0				
MTBF	Calculated per Mil Spec 217 E, or Bellcore at Ta=30°C	2			x10 ⁶ Hrs
	Demonstrated	1.3			x10 ⁶ Hrs

STANDARDS COMPLIANCE	
Standards	Conditions ⁴
UL/CSA 60950	Basic insulation

MANUFACTURING TESTING
<ul style="list-style-type: none"> ■ Burn-in test ■ Parametric test

SAFETY CONSIDERATIONS

This series of converters are certified to the standards and extent listed in the 'Standards Compliance' section in the table above. If this product is built into information technology equipment, the installation must comply with the above standard. Even though the product is safety certified to operate without an input fuse, it is recommended that an input fuse of 12A (max.) is used.

The output of the converter (Vo+/Vo-) is considered to remain within SELV limits when the input to the converter meets SELV or TNV-2 requirements. The converters and materials meet UL 94V-0 flammability ratings.

RoHS COMPLIANCE	
	<p>The EUS34-096 converter is in compliance with the European Union Directive 2002/95/EC (RoHS) with respect to the following substances: lead (Pb), cadmium (Cd), mercury (Hg), hexavalent chromium, polybrominated biphenyls (PBB) and polybrominated diphenyl ethers (PBDE).</p> <p>For further information, please visit www.cd4power.com/rohs</p>

1 VIN = 48Vdc, Ta = 25°C, Airflow = 200 LFM for all data unless otherwise noted.
 2 Input transient: if input voltage increases by 5V in 1µs, output over-current shut-down shall not be triggered (tested with Max. load and Max. output capacitance).
 3 Thermal shutdown is monitored at the Thermal Measurement Location (TML). See 'Mechanical Information' on page 3 for TML location.
 4 See 'Safety Considerations' shown on page 4.

Derating curves are conducted in a controlled environment. End application testing is required to ensure the Thermal Measurement Location temperature is below the maximum specified. Recommended airflow direction is from pin 1 to pin 3, or 3 to 1 (transversal to the unit).

PACKAGE SPECIFICATIONS

MECHANICAL DIMENSIONS

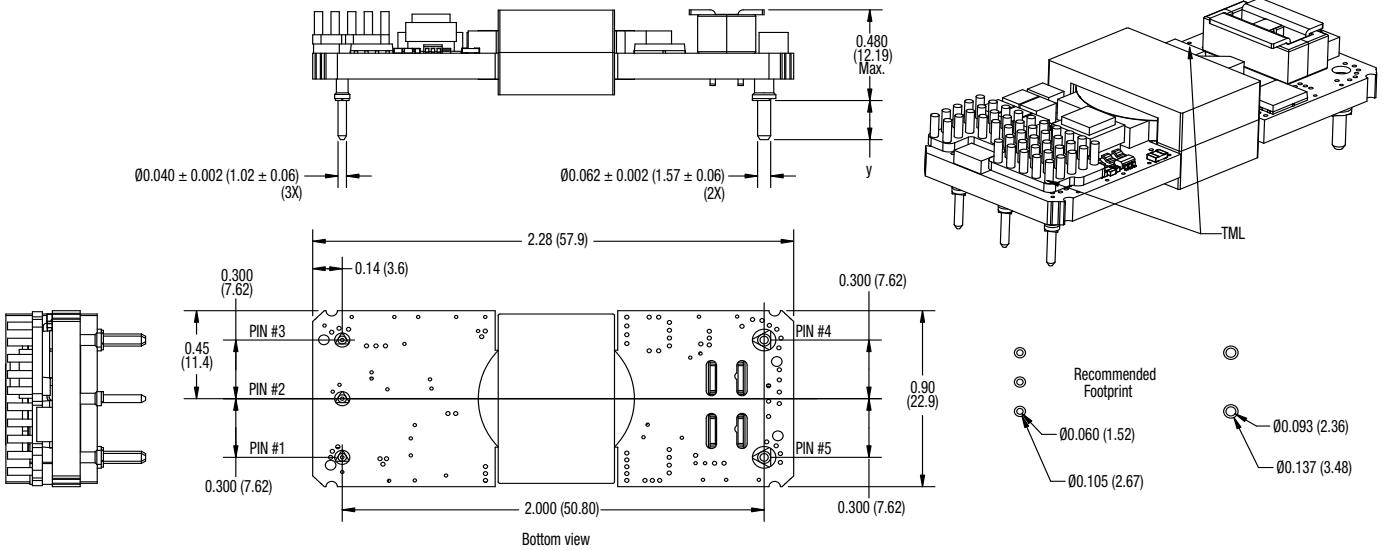

Dimensions: 2.3 (58.4) L x 1.45 (36.83) W x 0.48 (12.19) H
 All dimensions in inches (mm).
 Tolerance: X.X (X.XX) ±0.5 (0.2), X.XX (X.XXX) ±0.25 (0.010).
 Max. 0.480 (12.19) between highest component and mounting plane.

PIN CONNECTIONS

Pin	Assignment
1	+V _{IN}
2*	ON/OFF
3	-V _{IN}
4	-V _{OUT}
5	+V _{OUT}

* Referenced to Vi (-).
 Positive logic: Floating = Enabled
 Negative logic: Floating = Disabled

ORDERING INFORMATION

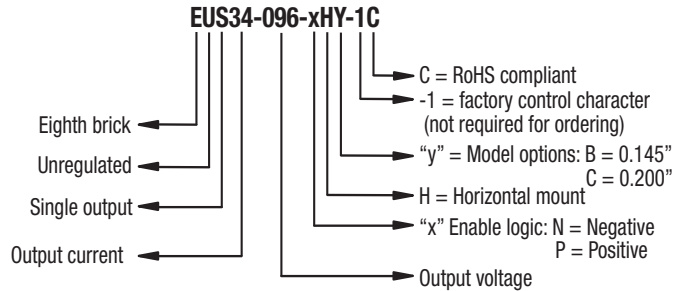

C&D Technologies, Inc reserve the right to alter or improve the specification, internal design or manufacturing process at any time, without notice. Please check with your supplier or visit our website to ensure that you have the current and complete specification for your product before use.

© C&D Technologies, Inc 2006 CDC_EUS34-096.3

No part of this publication may be copied, transmitted or stored in a retrieval system or reproduced in any way including, but not limited to, photography, photocopy, magnetic or other recording means, without prior written permission from C&D Technologies, Inc. Instructions for use are available from www.cd4power.com